

Pigoli



DAY  
— & —  
NIGHT

The logo for Pigoli, featuring the brand name in a white serif font on a dark red rectangular background with a wavy top edge.

Pigoli

A large, semi-transparent circular graphic overlay that frames the central text.

DAY  
.....&.....  
NIGHT



DAY

DAY. Divani e poltrone per un Living di alta classe stilistica ed inconfondibile qualità costruttiva artigianale. Le Collezioni Pigoli rappresentano la migliore selezione di modelli destinati ad ambientazioni di gusto internazionale di qualità superiore. Il piacere di scegliere i rivestimenti coordinati preferiti, in un'ampia e diversificata gamma disponibile a campionario, conferma la certezza di soluzioni sicuramente personalizzate ed all'altezza delle migliori aspettative d'arredo.

*DAY. Sofas crafted for a superior living experience characterized by a high-class stylishness and an unmistakably handcrafted build quality. Collezioni Pigoli represent the finest selection of choice models intended for superior quality environments with an international flavor. The pleasure of choosing one's favorite matching sets from a wide and diverse sample range confirms the soundness of customized solutions that undoubtedly live up to the highest furnishing expectations.*

AIRONE p. 34

CLEOS p. 14

ELISA p. 30

ETOILE p. 18

GISELLE con intaglio p. 10

GISELLE-RING p. 4

NINFEA p. 28

NINFEA con intaglio p. 26

NIVES p. 22

GISELLE-RING





KOS tavolino



NON VOGLIO ESSERE  
LA COSA PIÙ **BELLA**  
DELLA TUA **VITA**.  
VOGLIO ESSERE LA COSA  
CHE **SCEGLIERESTI** ANCORA,  
MALGRADO TUTTE LE  
**COSE** BELLE CHE HAI.

---

GISELLE con intaglio  
KOS TAVOLINO









ETOILE  
SOFIA PANCHETTA









L'ASPETTO DELLE COSE VARIA  
SECONDO LE LORO **EMOZIONI**,  
E COSÌ NOI VEDIAMO  
**MAGIA E BELLEZZA** IN LORO,  
MA, IN REALTÀ,  
MAGIA E BELLEZZA  
SONO IN **NOI**.

---

NINFEA con intaglio  
LINDOS TAVOLINO





NINFEA



CLEOS  
SIRIO TAVOLINO





ELISA  
SOFA PANCHETTA





AIRONE





# NIGHT

NIGHT. Una collezione notte nata per creare ambienti di raffinato gusto classico e sofisticata eleganza, in un concetto tutto italiano di arredo e di manifattura artigianale, per interpretare ambienti e stili di vita internazionali con la sapienza costruttiva del prodotto Made in Italy di Pigoli. "Sogni" che diventano realtà.

*NIGHT. A sleeping area collection designed for creating ambiances with a refined classical flavor and sophisticated elegance, in an all-Italian concept of traditional furniture-making and artisan craftsmanship, as well as interpreting settings and lifestyles from around the world with the constructive know-how of "Made in Italy" products by Pigoli. "Dreams" do come true.*

BRAMANTE p. 58

CANOVA p. 48

CLEOS-BED p. 67

IKARUS-BED p. 46

KRONOS-BED p. 42

MATISSE-BED p. 52

PANDORA p. 60

PETRA p. 38

PRELUDIO p. 64

CARMEN p. 70

TOSCA p. 74

PETRA  
KOS TAVOLINO  
MOON POUF





KRONOS-BED









CANOVA





LA **FELICITÀ** STA NEL **GUSTO**  
E NON NELLE COSE;  
SI È **FELICI** PERCHÈ SI HA  
CIÒ CHE CI **PIACE**,  
E NON PERCHÈ SI HA CIÒ  
CHE GLI ALTRI  
TROVANO **PIACEVOLE**.

---

MATISSE-BED

KOS TAVOLINO





MATISSE





LA **BELLEZZA** È L'UNICA COSA  
CONTRO CUI LA **FORZA**  
DEL **TEMPO** SIA VANA.  
CIÒ CHE È BELLO  
È UNA **GIOIA** PER TUTTE LE STAGIONI,  
ED È UN POSSESSO  
PER TUTTA L'**ETERNITÀ**.

---

BRAMANTE  
MOON POUF



PANDORA







CAROLA poltrona



PRELUDIO





CLEOS-BED  
LADY PANCHETTA



CARMEN

DIVANO/LETTO





TOSCA

DIVANO/LETTO



## Nozioni tecniche/Technical specification

### Carmen divano-letto/sofa-bed\_70

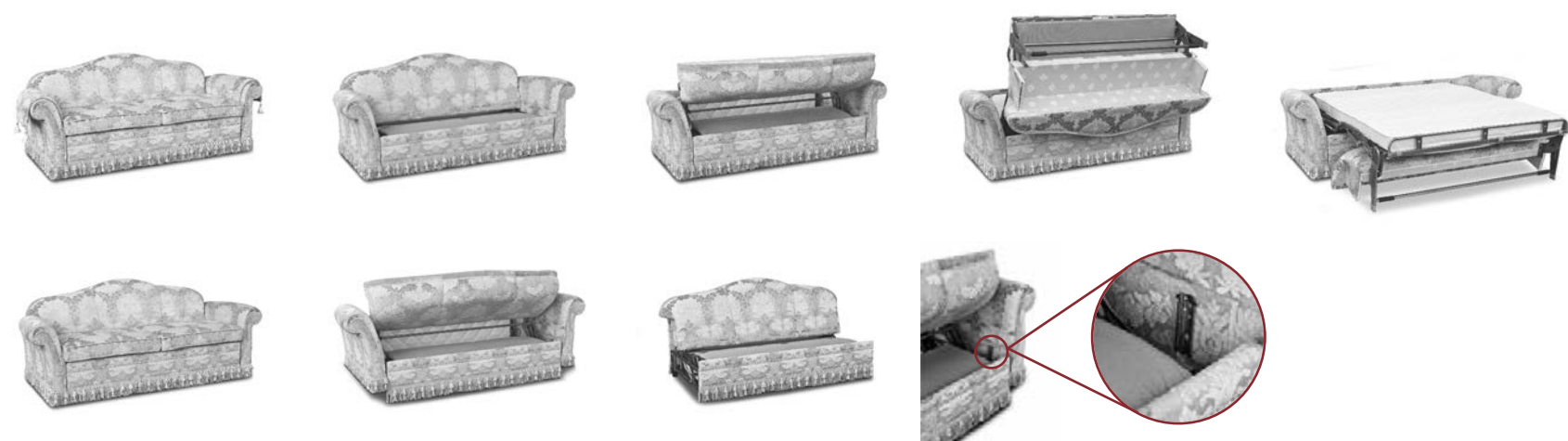
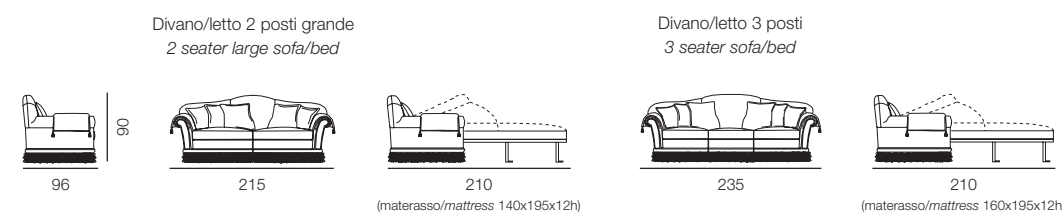

 Divano smontabile: braccioli staccabili per agevolare il trasporto e il posizionamento nell'ambiente.  
Sofa disassembling: detachable arms to allow easy transport and placement.

### Tosca divano-letto/sofa-bed\_74

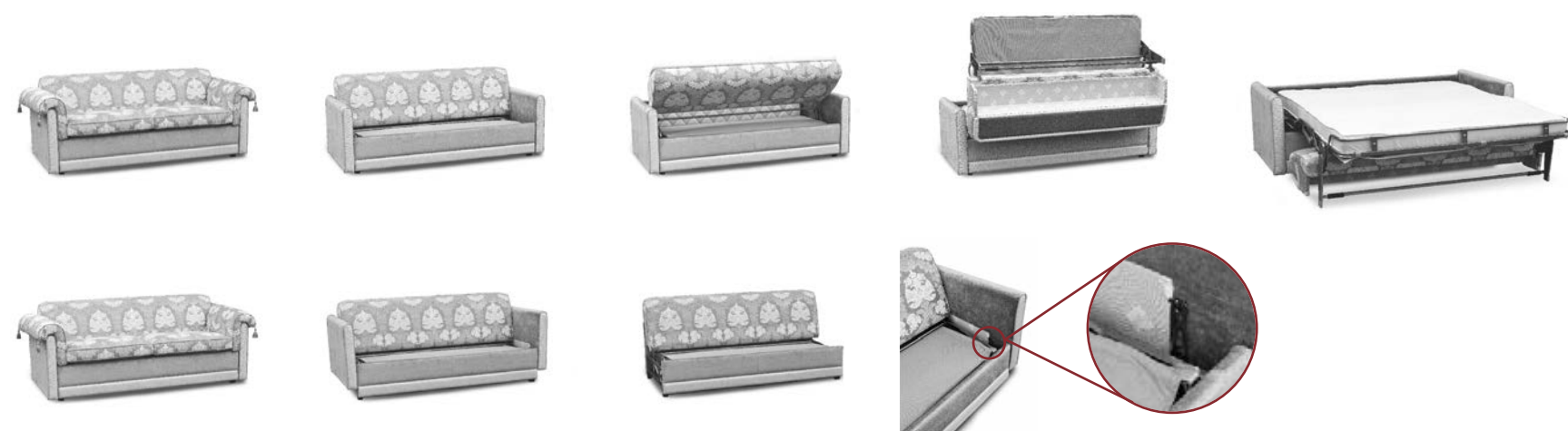
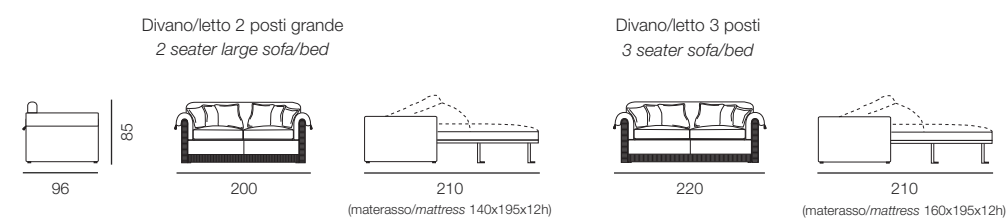

 Divano smontabile: braccioli staccabili per agevolare il trasporto e il posizionamento nell'ambiente.  
Sofa disassembling: detachable arms to allow easy transport and placement.

La produzione di ogni articolo originale delle collezioni **Pigoli Salotti** è caratterizzata dai più alti standards qualitativi, tipici della migliore lavorazione artigianale che prevede l'impiego esclusivo di materie prime selezionate, garantite nell'affidabilità tecnologica per assicurarne una lunga durata nel tempo.

Ecco le più importanti caratteristiche, riscontrabili in ogni modello:

- Struttura portante in legno massello
- Molleggio a molle biconiche in acciaio e cinghie elastiche di supporto e tenuta indeformabili
- Imbottiture di sostegno interne e braccioli in poliuretano a quote e densità differenziate
- Cuscini schienale e seduta dotati di fodera bianca in cotone 100% e imbottitura a settori separati in piuma naturale, con inserto di sostegno in poliuretano oppure in poliuretano indeformabile a quote differenziate. La piuma utilizzata è garantita da Assopiuma.
- Ampia scelta di rivestimenti in tessuto o pelle disponibili a piacere nel ricco campionario o, eventualmente, con materiali forniti dal cliente.

A seguito di eventuali aggiornamenti tecnico-produttivi la **Pigoli Salotti** si riserva la facoltà di modificare le caratteristiche tecniche degli articoli di sua produzione e di apportare, senza alcun preavviso, variazioni nell'assortimento dei prodotti.

Una tolleranza del 3% sulle misure indicate è da considerarsi accettabile.

Any original product processing by **Pigoli Salotti** complies with the highest possible quality standards, unique and typical of any traditional handicraft processing technique: only exclusively selected raw materials are used, guaranteed by a consistent technological reliability, to last in time.

The leading features in any model mainly are:

- A self-standing solid wood structure
- Biconical steel springs and supporting and tight belts, which keep their shape in time
- Internal upholstery and polyurethane foam arms in different thickness and density
- Back and seat cushions covered with a 100% white cotton lining. Natural down with separate section padding with supporting insert in polyurethane foam or in shape-retaining multi-density polyurethane foam. Down guaranteed by Assopiuma.
- A wide range of fabric or leather covering, in the many materials available in the company collection or possibly any customer own material.

**Pigoli Salotti** reserves the right of modifying the technical characteristics of its production item and introducing changes in its products stock without notice as a result of a possible technical and production updating. A 3% allowance with respect the measurements is considered acceptable.



cassone guardaroba  
padded cupboard bed



cassone con rete a doghe  
padded bed with woodslats



# DAY

## Airone<sub>34</sub>

I terminali e la dormeuse del modello Airone sono disponibile in versione DX o SX.  
Ending elements and dormeuse for model Airone are available in left or right version.

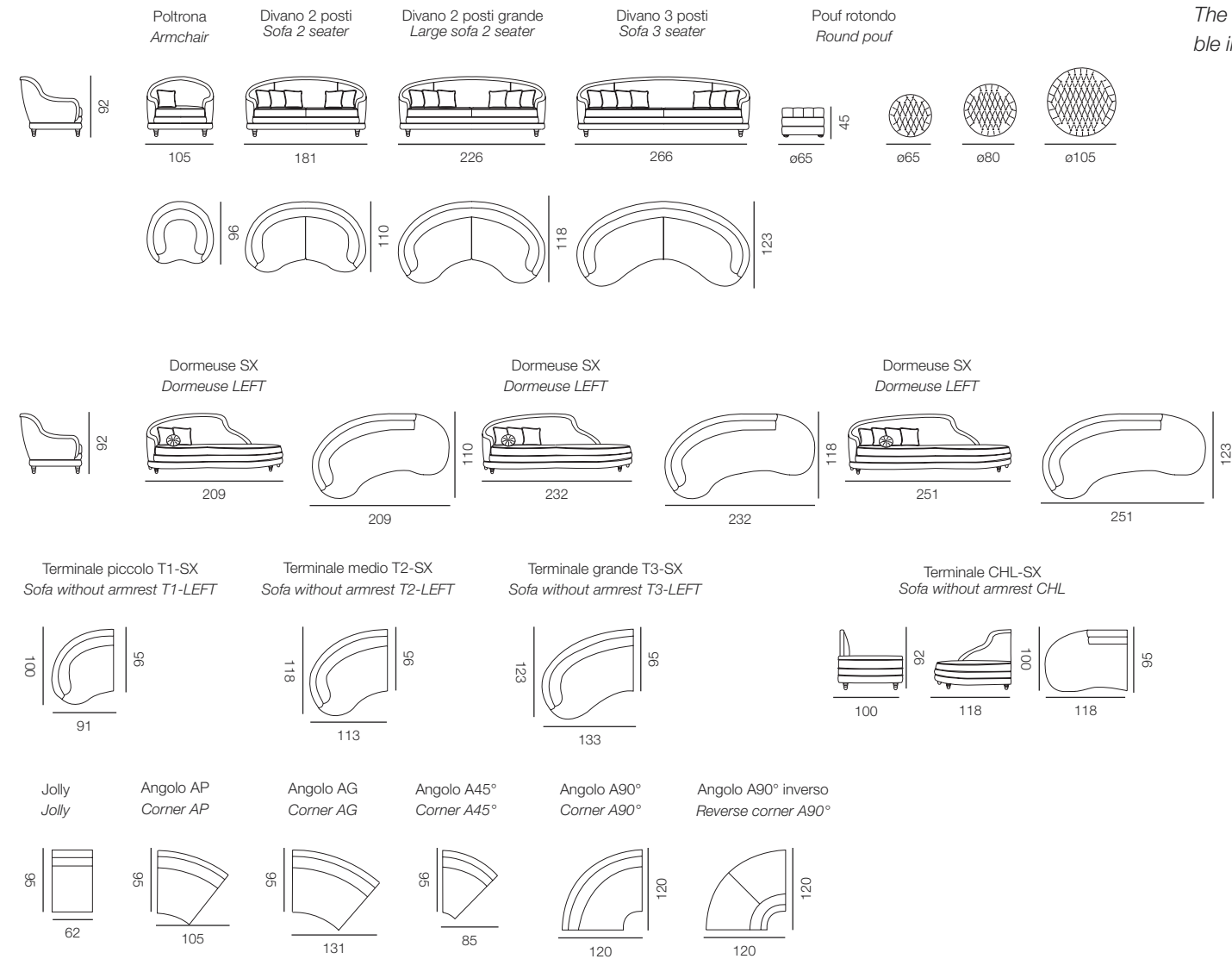

Il modello Airone è disponibile anche in versione capitonné.

The Airone model is also available in the pinch quilted version.

## Cleos<sub>14</sub>

I terminali del modello Cleos sono disponibile in versione DX o SX.  
Ending elements for model Cleos are available in left or right version.

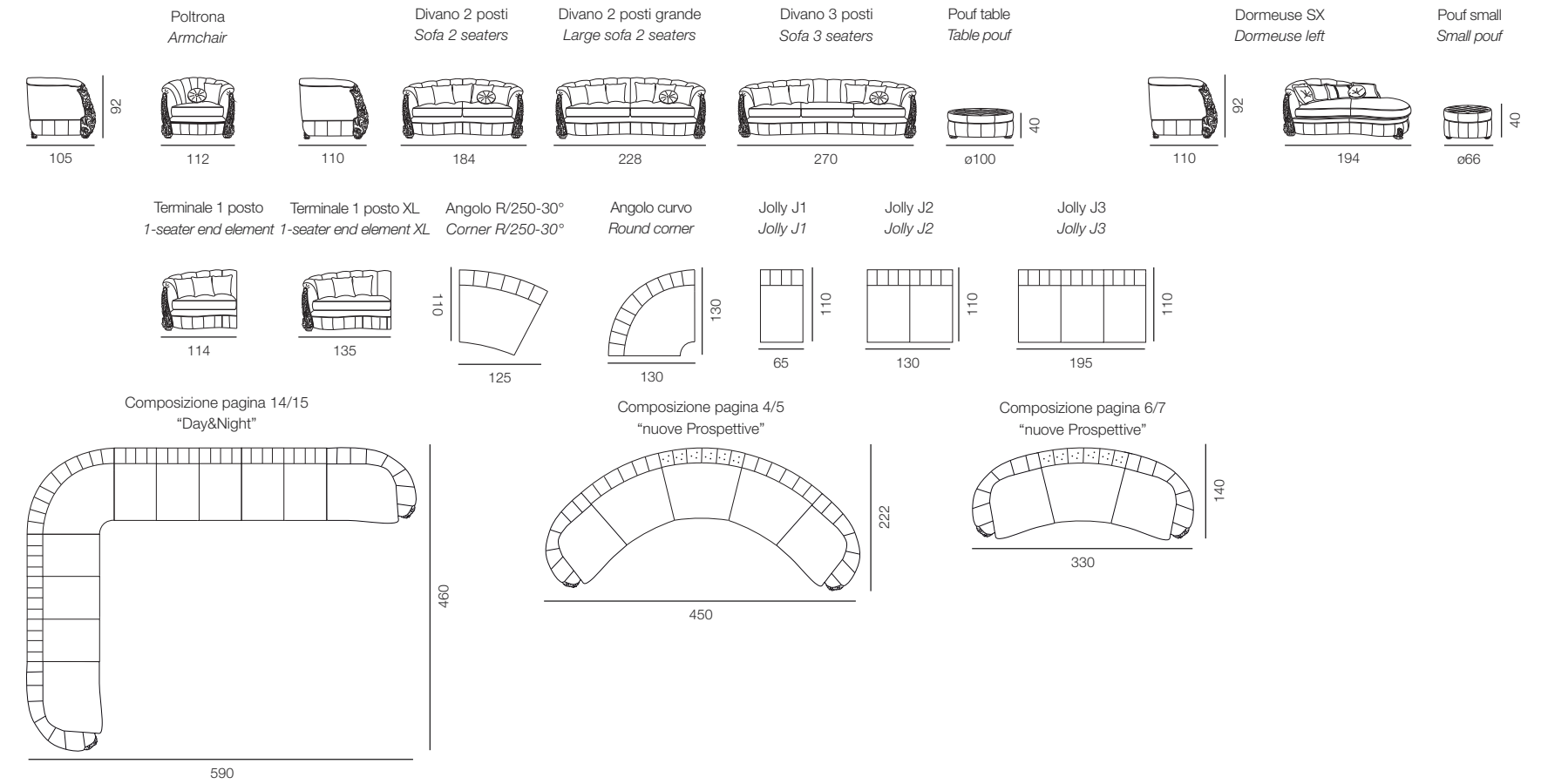

## Elisa<sub>30</sub>

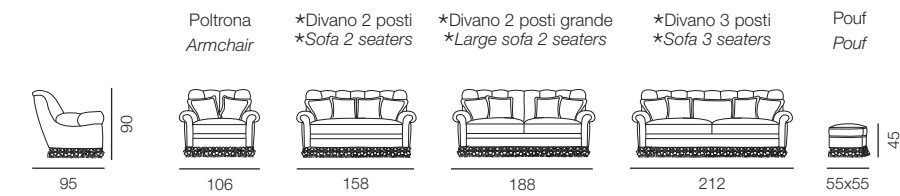

\* Disponibile anche in versione trasformabile a letto, senza modifiche nell'estetica.

\* Also available in the bed version, without aesthetic changes.

## Etoile<sub>18</sub>

I terminali del modello Etoile sono disponibile in versione DX o SX.  
Ending elements for model Etoile are available in left or right version.

## Etoile capitonné

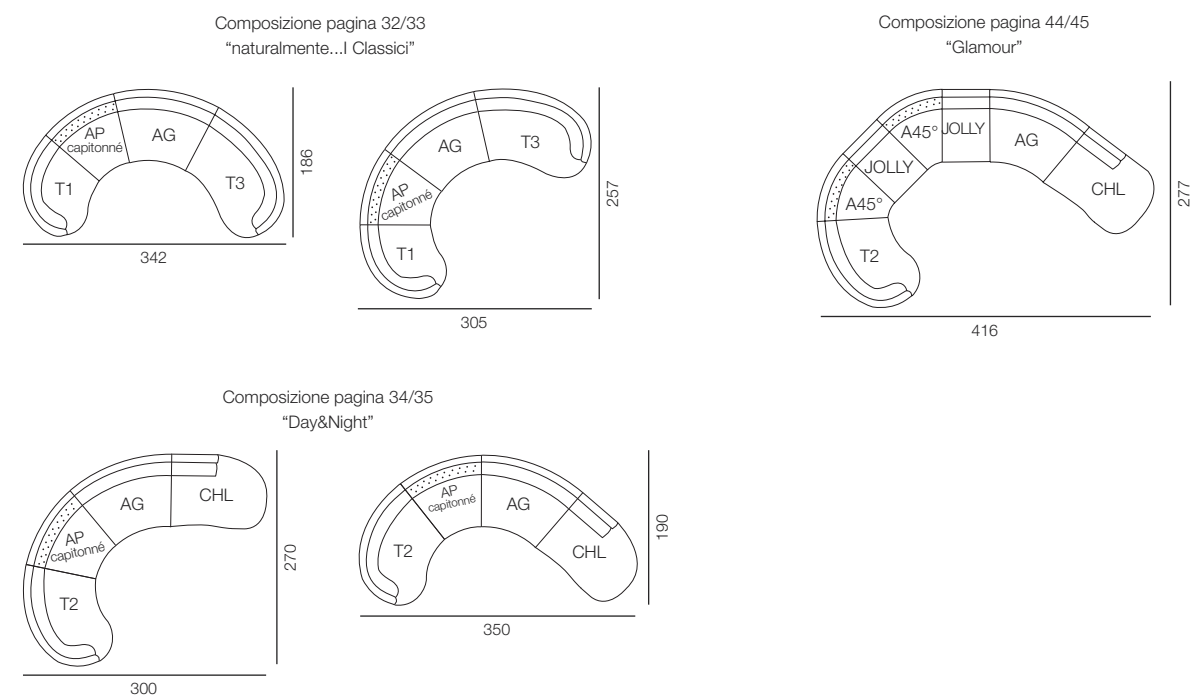

Il modello Etoile è disponibile anche in versione capitonné.

The Etoile model is also available in the pinch quilted version.

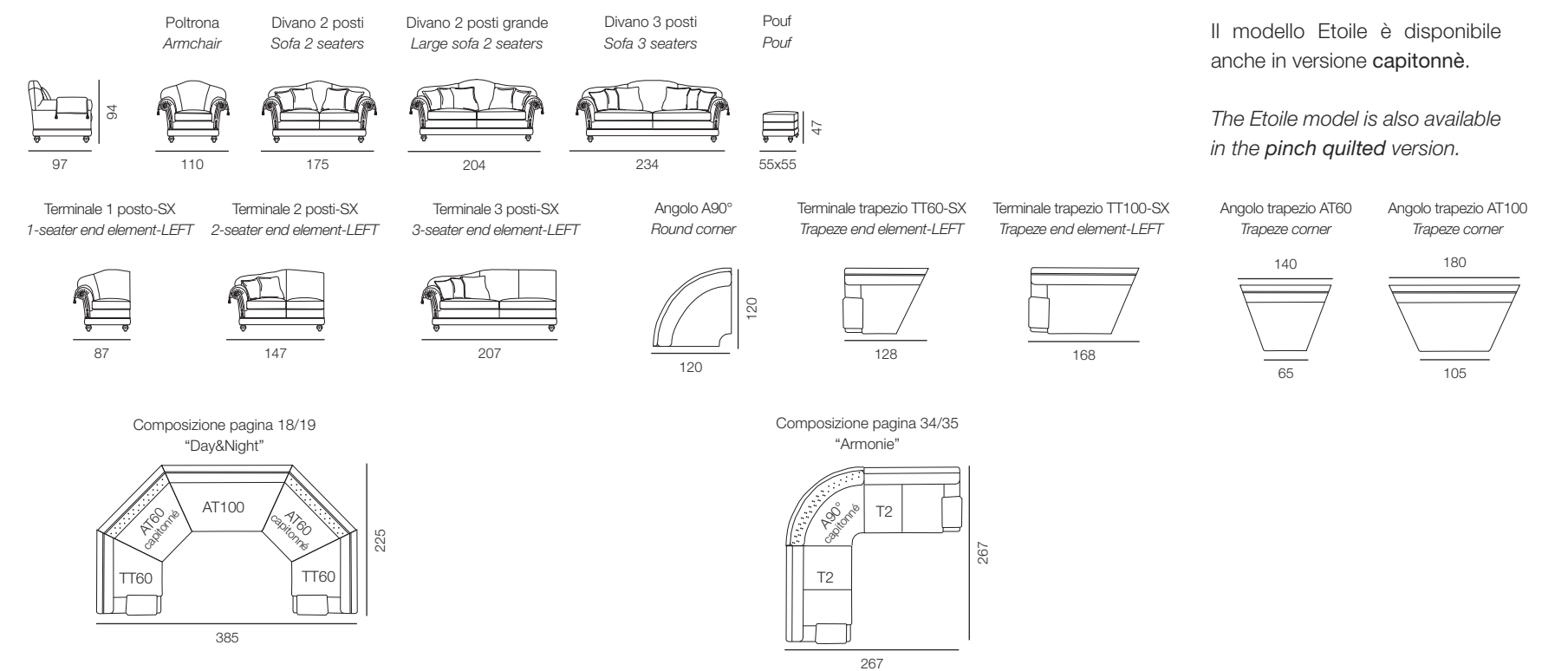

## Giselle

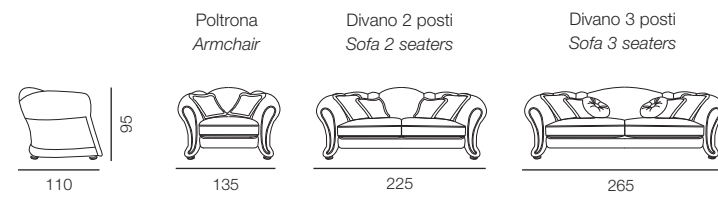

## Giselle-Ring<sub>4</sub>

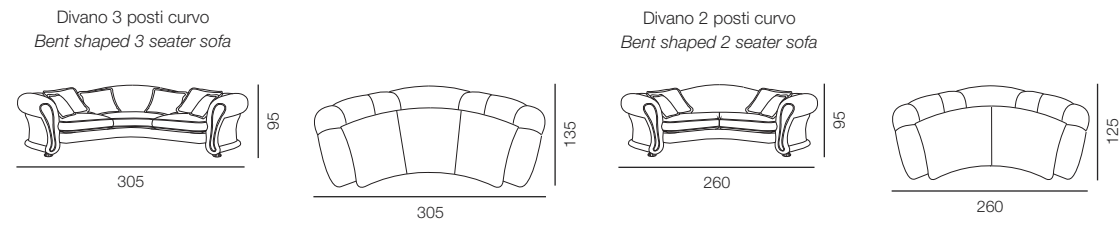

## Giselle con intaglio<sub>10</sub>

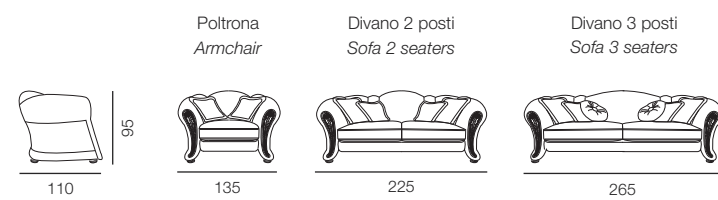

## Giselle-Ring con intaglio

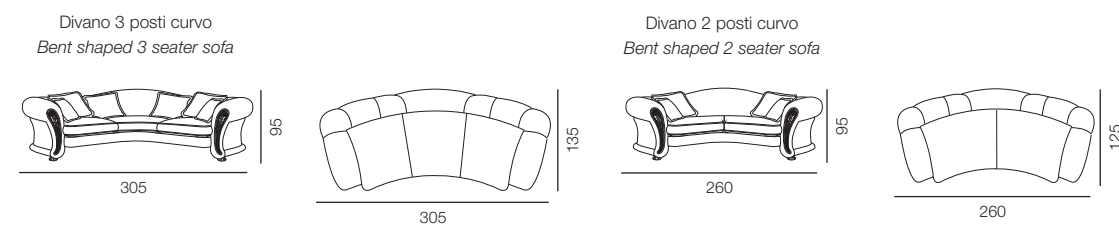

## Matisse<sub>54</sub>

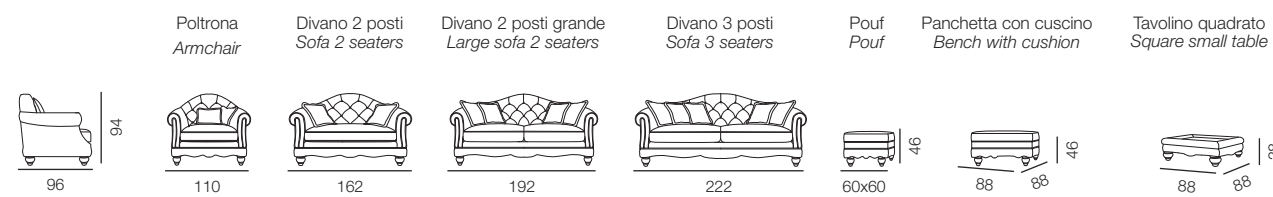

## Ninfea<sub>28</sub>

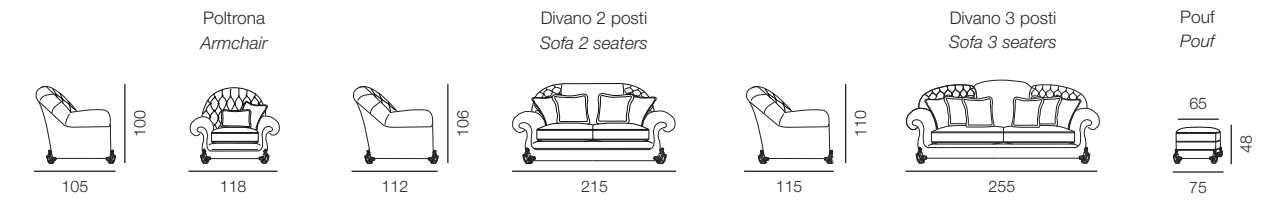

## Ninfea con intaglio<sub>26</sub>

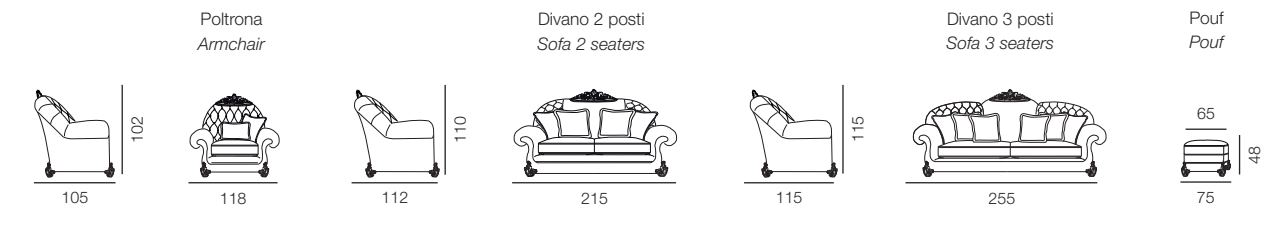

## Nives<sub>22</sub>

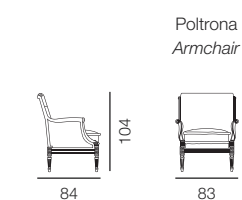

## Nives capitonné

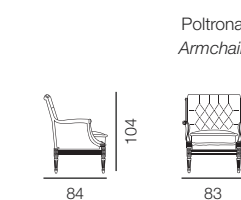

## Sofia<sub>18</sub>

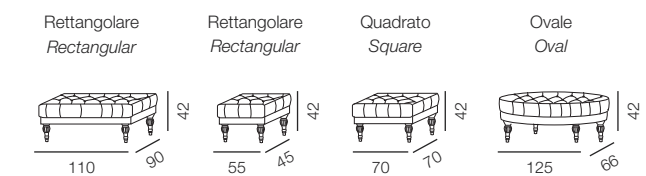

## Moon<sub>54</sub>

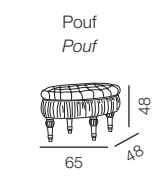

## Kos tavolino<sub>7/10/23</sub>

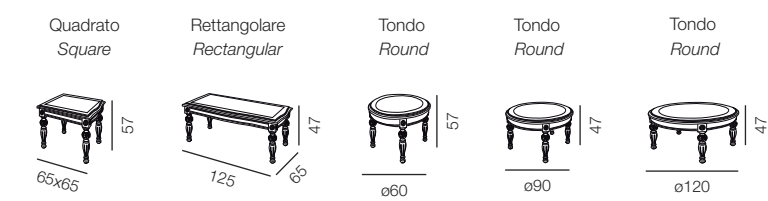

Il modello Kos è disponibile in versione con piano marmo o con piano cristallo.

The Kos model is available in marble or glass top version.

## Lindos tavolino<sub>26</sub>

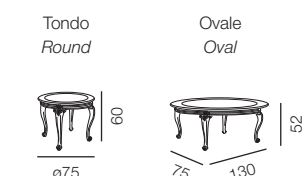

Il modello Lindos è disponibile in versione con piano marmo o con piano cristallo.

The Lindos model is available in marble or glass top version.

## Sirio tavolino<sub>14</sub>

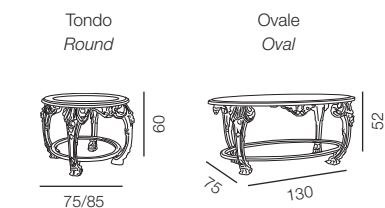

Il modello Sirio è disponibile in versione con piano marmo o con piano cristallo.

The Sirio model is available in marble or glass top version.

# NIGHT

## Bramante\_58

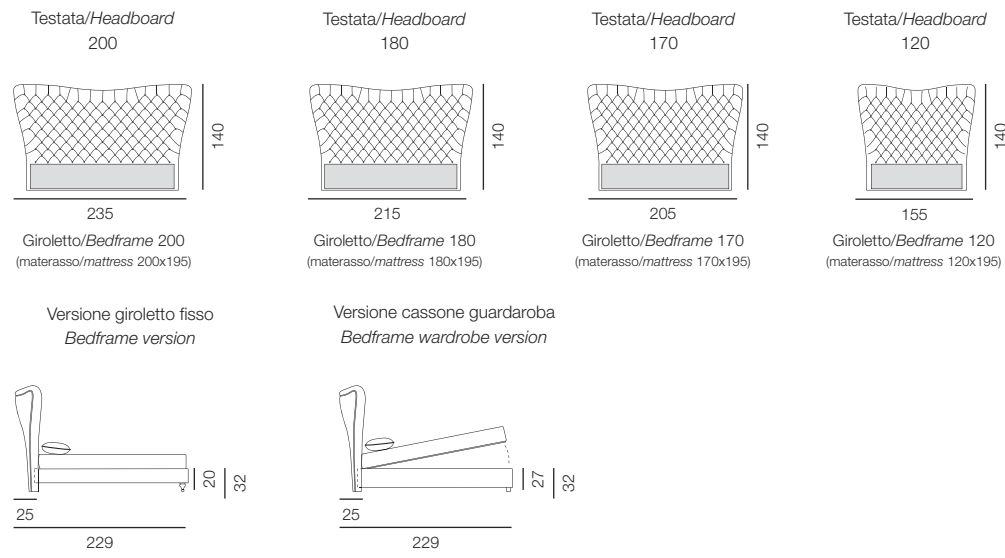

## Canova\_48

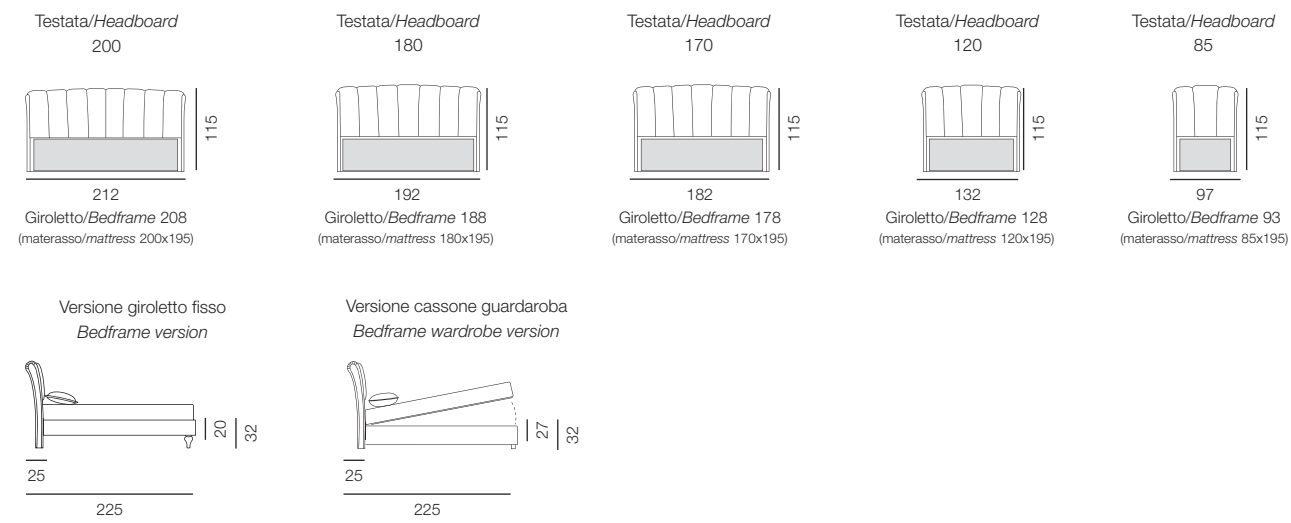

## Cleos-Bed\_67

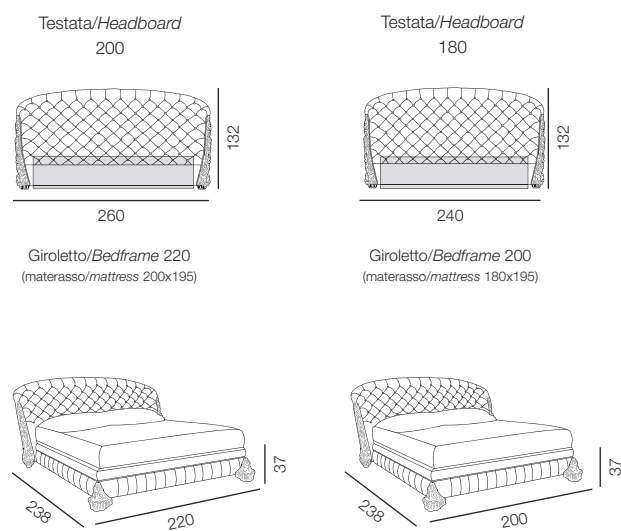

## Lady panchetta\_66

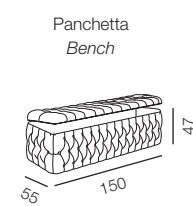

## Ikarus-Bed\_46

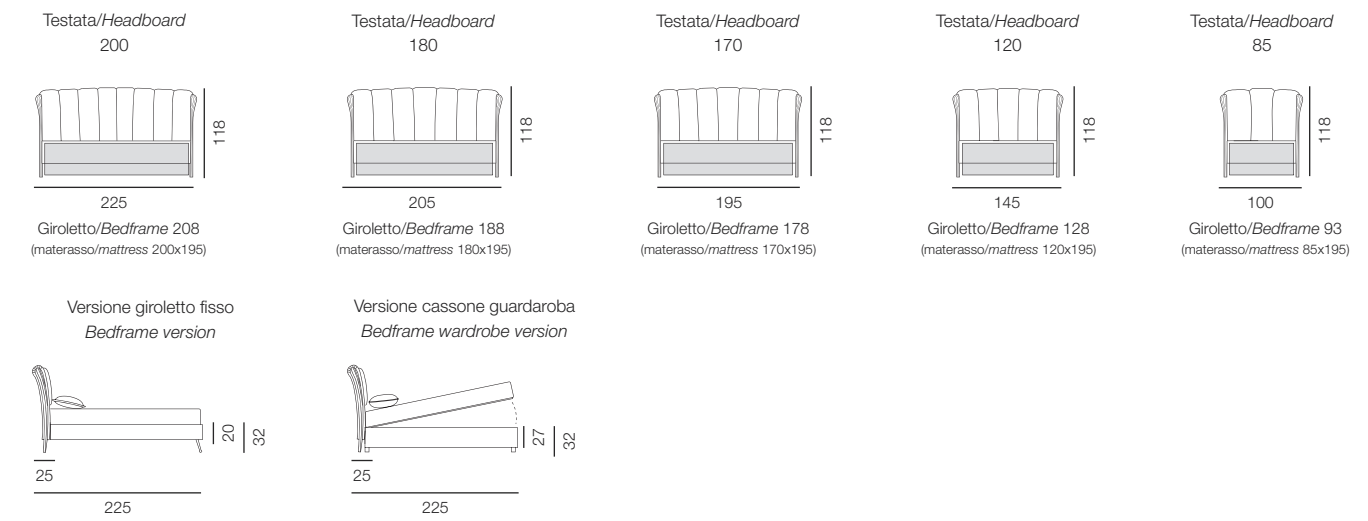

## Kronos-Bed\_42

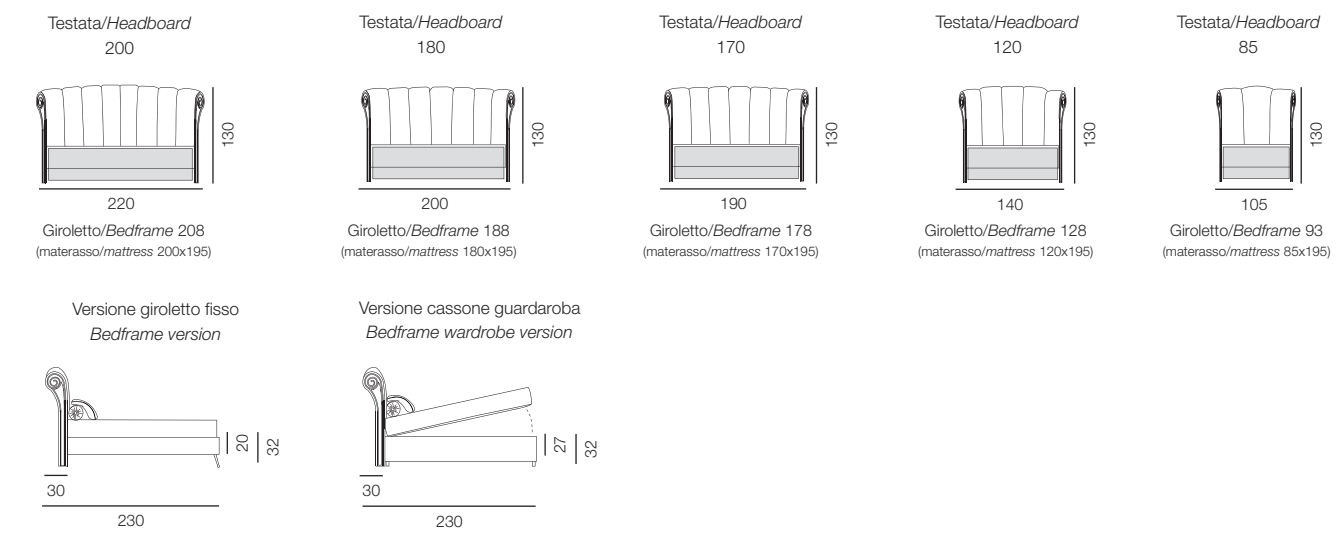

## Matisse-Bed\_52

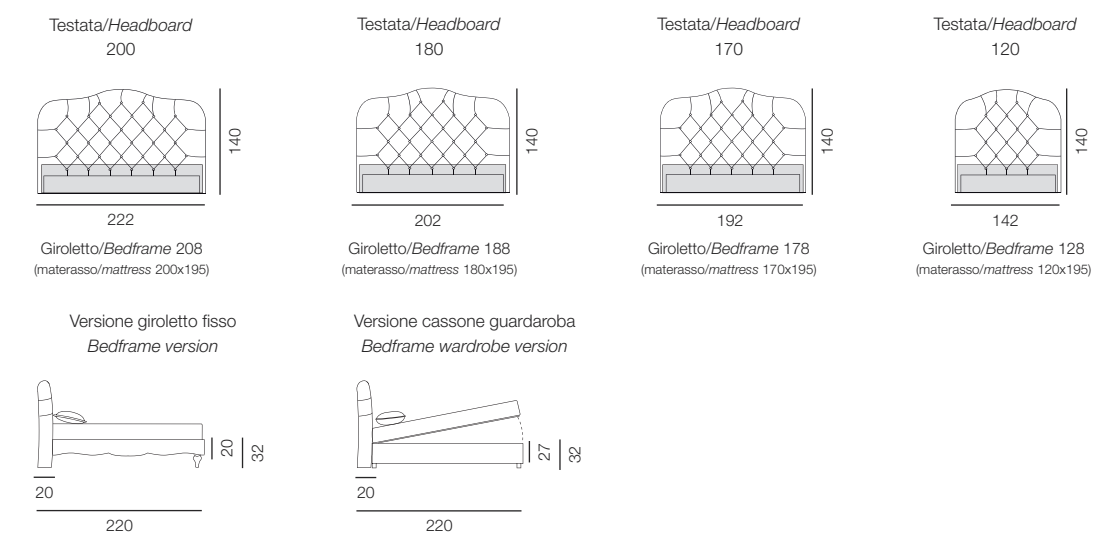

## LA 581 specchio\_53

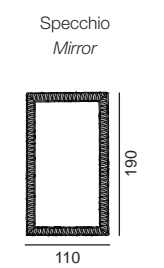

## Pandora<sub>60</sub>

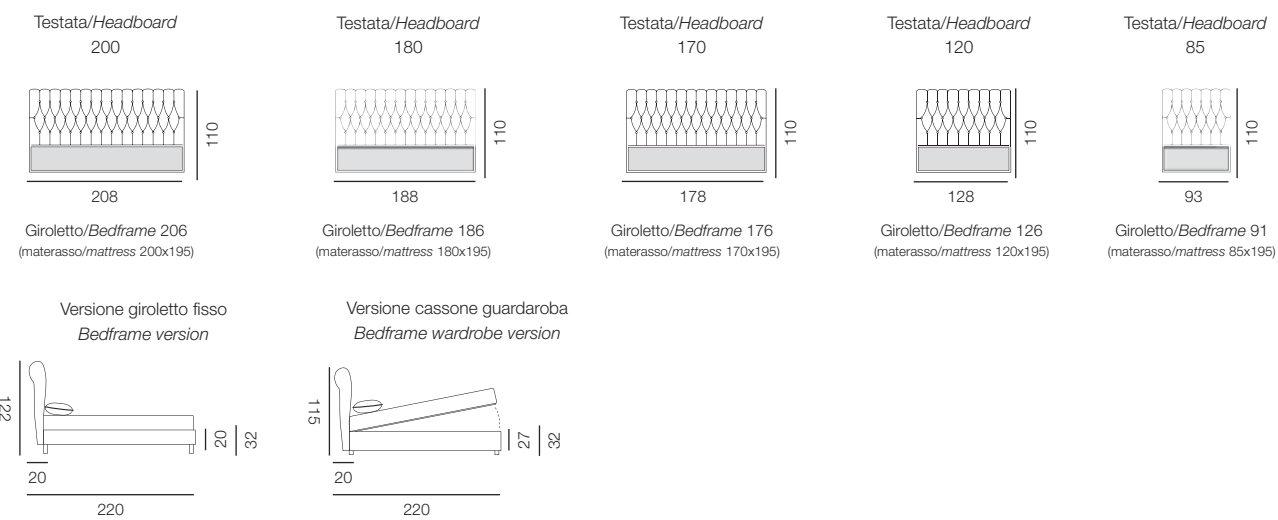

## Carola<sub>62</sub>

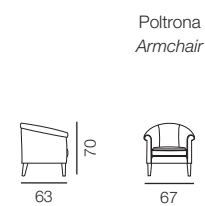

## Testate sfoderabili/Head with removable cover

### Antigua

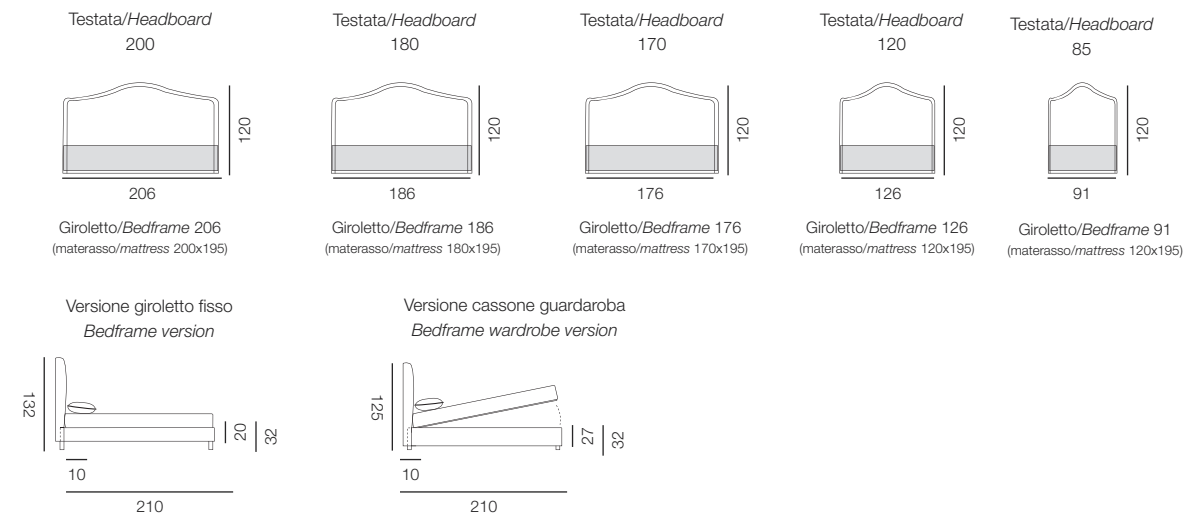

## Petra<sub>38</sub>

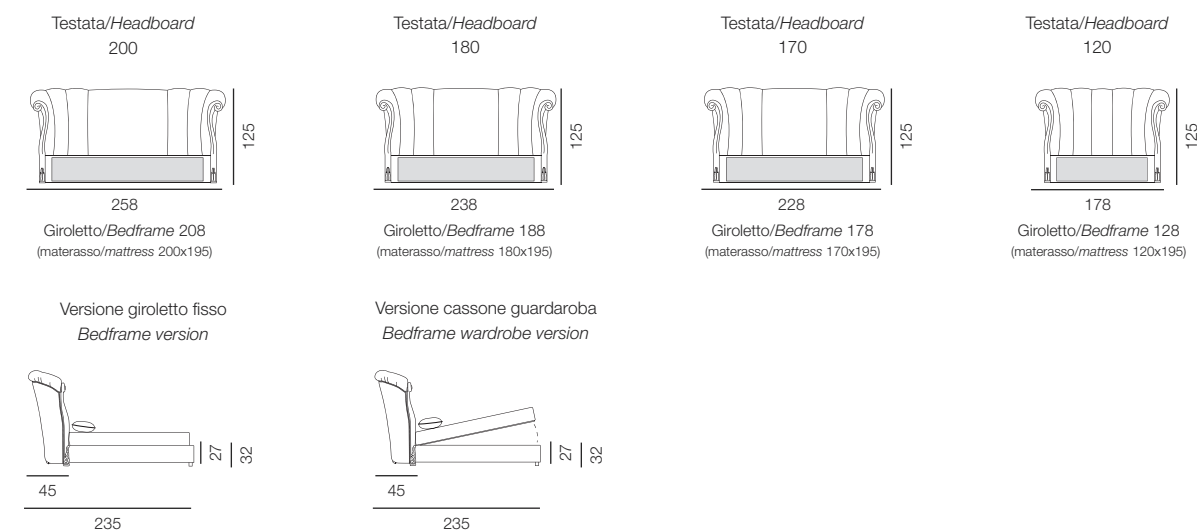

### Marbella

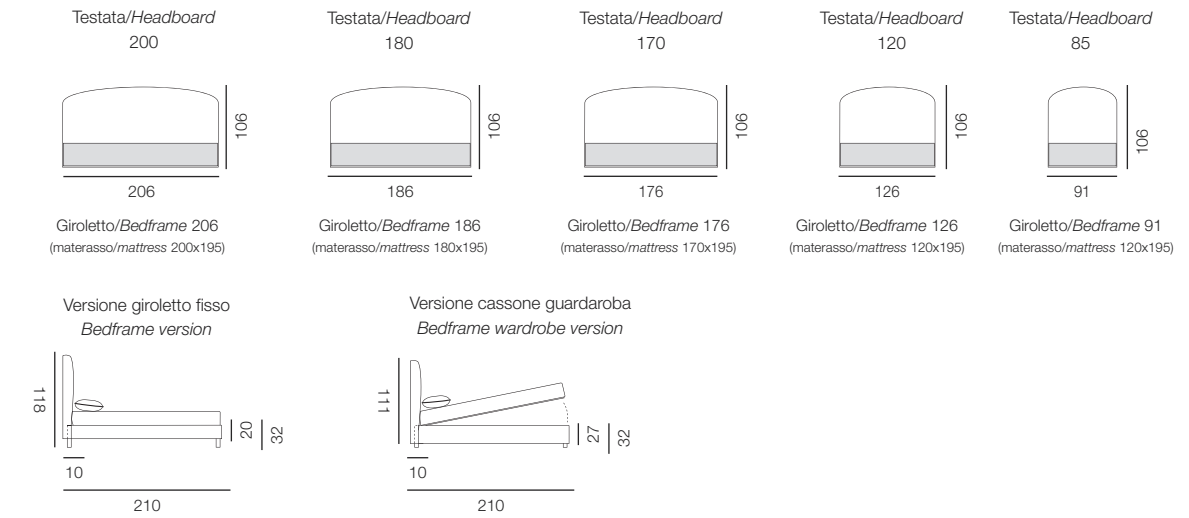

## Preludio<sub>64</sub>

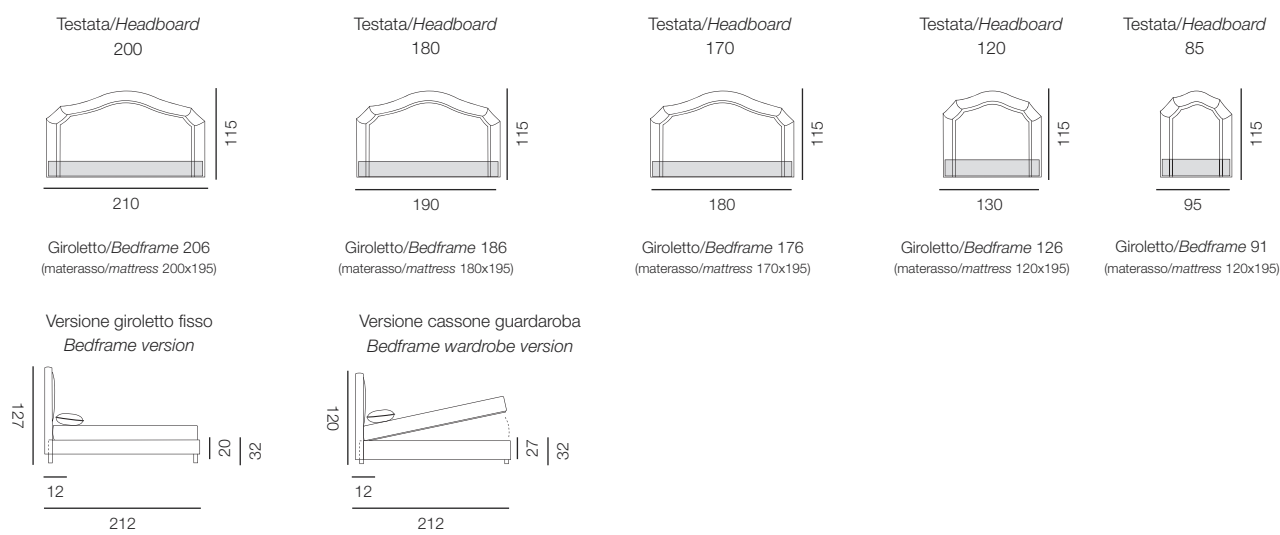

### Minorca

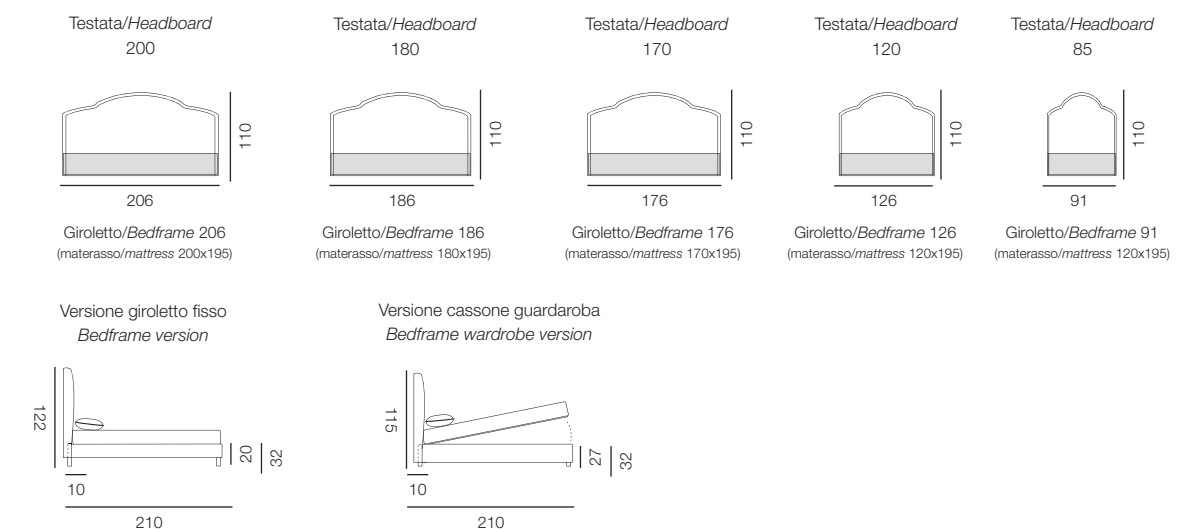

Finiture\_Finishing



LUC 01 Noce\_Walnut



LUC 02 Noce scuro\_Dark walnut



LUC 10 Noce e oro\_Walnut and gold



LUC 03 Ciliegio\_Cherry



LUC 11 Decapè chiaro\_Light pickled finish



LUC 12 Decapè scuro\_Dark pickled finish



LUC 15 Wengè\_Wengè



LUC 18 Wengè e argento\_Wengè and silver



LUC 19 Mogano\_Mahogany

Finiture\_Finishing



LAC 20 Argento foglia\_Silver leaf



LAC 24 Argento Mecca\_Mecca's silver



LAC 25 Argento spugnato\_Sponged silver



LAC 30 Oro foglia\_Gold leaf



LAC 31 Oro patinato\_Patinated gold



LAC 45 Oro sbiancato\_White gold



LAC 40 Avorio\_Ivory



LAC 42 Avorio e oro\_Ivory and gold



LAC 44 Avorio e argento\_Ivory and silver

I riferimenti colore sono puramente indicativi.  
The colours samples are only indicative.



Pigoli Salotti s.r.l.  
Via Como, 99  
20821 Meda (MB) ITALY  
Tel. +39 0362 71701  
Fax + 39 0362 340372  
[www.pigoli.com](http://www.pigoli.com)  
[info@pigoli.com](mailto:info@pigoli.com)